

Mounting instruction for Item No. 6250/7 Front Tuning disk brake Monster Truck, set

Tuning disk brake for the front wheels suitable for the Monster models with double shock absorbers. For mounting the alloy uprights 6103/6 are necessary. To use this brake we recommend a regulating power of at least 7-8 kg of the throttle/brake servo in order to achieve the required brake power.

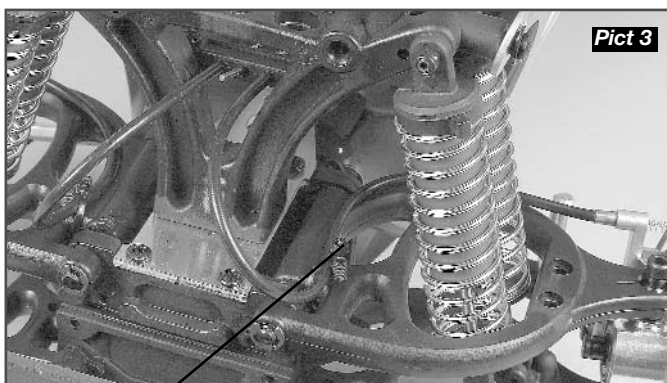

FG ModellSport-Vertriebs-GmbH
Spanningerstr. 2
73650 Winterbach-Germany
Phone: +49 7181 9677-0
Fax: +49 7181 9677-20
info@fg-modellsport.de
www.fg-modellsport.de
www.fg-team.com

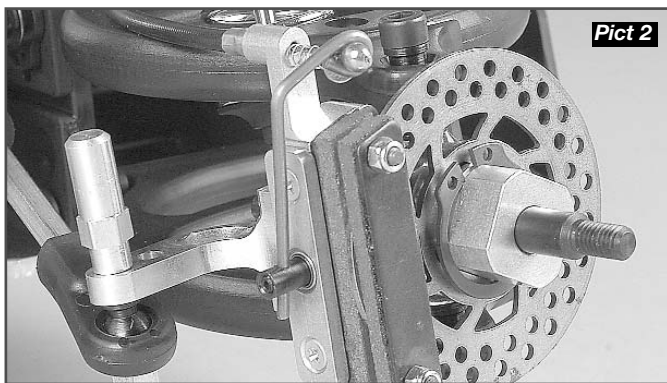
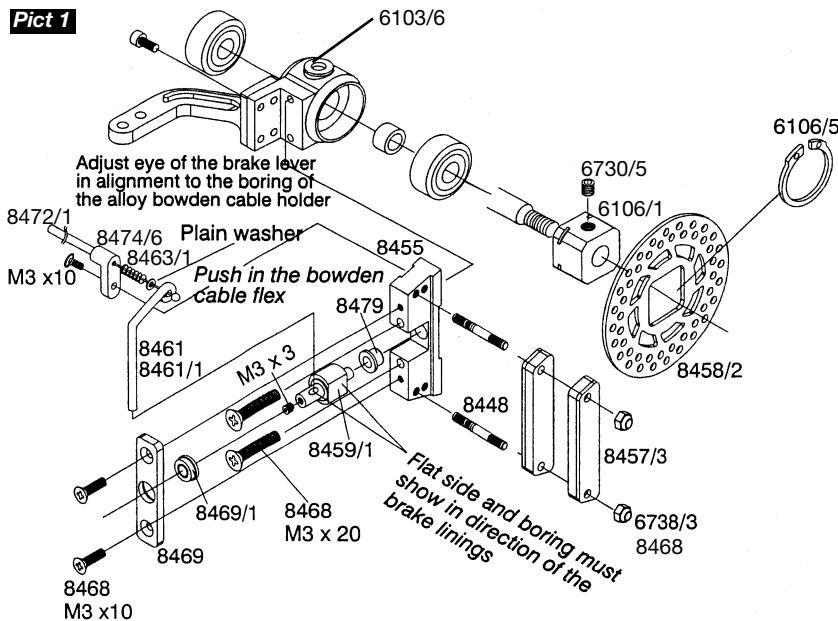

6565/16
8093 10451/5 Bend the servo rods as shown on the picture.

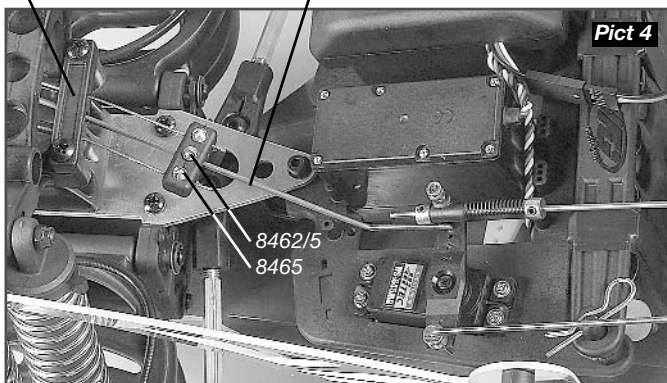

Spare parts

6020	Alloy collets 2,1mm, 5pcs.
6106/5	Securing ring f. square wheel, 4pcs.
6565/16	Cable clamps black 2,5x165, 50pcs.
6738/3	Self-locking hexagon nut M3, 15pcs.
8093	Brake guide rail, 1pce.
8448	Stud bolt f. brake lining, 4pcs.
8455	Alloy brake caliper f. fr. disk brake, 1pce.
8457/3	Comp. brake lining glued, 4pcs.
8458/2	Tuning brake disk, lasered, 2pcs.
8459/1	Brake shafts, 2pcs.
8461	Brake lever and servo rods, 2pcs.
8461/1	Brake lever f. fr. + r. disk brake, 2pcs.
8462/5	Balance, 2pcs.
8463/1	Pressure spring 0,25x3,2x14mm, 2pcs.
8465	Collet set, 4pcs.
8468	Screw set f. f. + r. disk brake
8469	Guiding plate, ball-bearing, 2pcs.
8469/1	Ball bearing flange f. guiding plate, 2pcs.
8472/1	Flex. lg. bowden cable f. r. disk br., 1pce.
8474/6	All. bowden cable hold. lg. f. 1:6/F1, 2pcs.
8479	Steel bush f. brake caliper, 2pcs.
10451/5	Servo rods f. disk brake, 2pcs.

Mounting

Mount the following parts as shown on Picture 1 and Picture 2. Secure all metric screws with screw retention lacquer medium. Fix brake caliper 8455 with impressed bearing bush 8479 at the alloy uprights 6103/6. Install the long alloy bowden cable holder 8474/6 as shown on the picture. Screw the stud bolt 8448 with the longer threaded portion into the brake caliper and put some screw retention lacquer (medium strong) on the thread. The brake shafts 8459/1 exist in two different versions. When you mount the brake shafts into the brake caliper 8455 make sure the flat area as well as the boring for the brake lever 8461/1 show to the outside or rather to the brake linings 8457/3. Now screw guiding plate 8469 with ball bearing 8469/1 on the brake caliper.

Pull the bowden cable flex completely out of the bowden cable pipe, now screw the bowden cable pipe into the bowden cable holder. Mount brake lever 8461/1 as shown on Picture 2 and fix it with the headless pin M3x3. The eye of the brake lever should be in alignment with the boring of the bowden cable holder. Now push the bowden cable flex as shown on the picture first through the eye of the brake lever 8461/1, then through the washer, pressure spring 8463/1, bowden cable holder and all completely into the bowden cable pipe.

Mount the square wheel driver as shown on the picture. Now install the brake linings 8457/3 (brake lining in direction to the brake disk) with the brake disk 8458/2. Press the brake linings with the intermediate brake disk slightly together. Then screw the M3 stop nut on, but make sure the brake disk can still be moved freely.

Screw the brake guide rail 8093 on the front shock mount as shown on the picture. Press the bowden cable pipes into the borings of the brake guide rail as shown on Picture 3 and 4. Important! Fix the bowden cable pipe in true alignment with the boring of the brake guide rail and press it in slowly with rotations to the left and right. Then mount the rods, bowden cables, throttle pivot posts and collets as shown on the picture. Fix the bowden cables with the enclosed cable clamps at the upright in a way that a maximum degree of lock is ensured without a buckling of the bowden cables.

Adjustment of the brake: In neutral position of the throttle lever (transmitter) both brake disks should be able to turn freely. In direction of the brake (transmitter - throttle lever backwards) both brakes should pursue an equal braking effect on to the disks. A one-sided braking effect can be adjusted at the balance or at the M3 stop nuts of the brake linings. Too much or too little braking effect of both brakes can be adjusted through loosening and displacing of the middle collet and the balance.